

# OMNInet™ Fiber-Optic Network Installation Guide

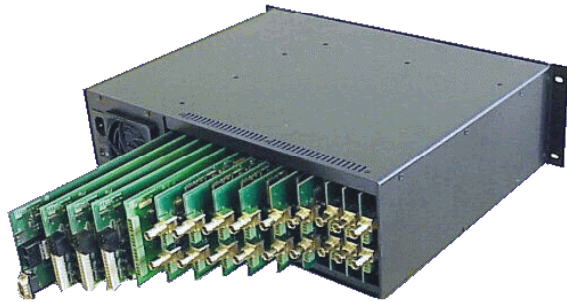
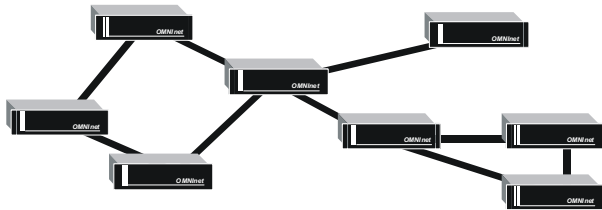

**CHSYS02**

## Contents

Warnings and Cautions .....	2
About this Guide .....	3
About the Product .....	3
Installation .....	3
Parts Required .....	3
Tools Required .....	3
Installing the OMNInet Chassis .....	4
Connecting Fiber Cables .....	4
Connecting Signal Cables .....	4
Connecting the Host PC .....	4
OMNInet System Components .....	5
OCHSYS02 System Rack Chassis .....	5
PSA02 Universal AC Input Power Supply Module .....	5
FC101 Network Interface Module .....	6
ADV232 2-Channel Video Compression Module .....	6
DAV232 2-Channel Video Decompression Module .....	6
ADA424 Audio Input Module .....	7
DAA424 Audio Output Module .....	7
SSD002 2-Channel Data I/O Module .....	7
Troubleshooting .....	8
Service .....	10
Removing the Power Supply Module .....	10
Installing the Power Supply Module .....	10
Setting or Verifying the Chassis Address .....	10
Installing a Module Card .....	11
Removing a Module Card .....	11
Specifications .....	12
Electrical .....	12
Environmental .....	12
Mechanical .....	12
Connectors .....	12
Operational .....	12
Part Numbers .....	13
Declarations .....	13
Regulatory Compliance .....	13
Other Declarations .....	13

## Warnings and Cautions



**Class 1 Laser Product**

**Laser Klasse 1 Produkt**

**WARNING:** INVISIBLE LASER RADIATION. Lasers emit invisible radiation from the aperture when no fiber-optic cable is connected. When removing cables do not stare into the open apertures. In addition, install protective aperture covers to fiber ports with no cable connected.

Français: **PRÉVENIR:** RAYONNEMENT DE LASER INVISIBLE. Les lasers émettent le rayonnement invisible de l'ouverture quand aucun câble fiber-optic n'est relié. En enlevant des câbles ne regardez pas fixement dans les ouvertures ouvertes. En outre, installez les couvertures protectrices d'ouverture sur des ports de fibre sans le câble relié.

Deutsch: **WARNING:** UNSICHTBARE LASERSTRAHLUNG. Laser strahlen unsichtbare Strahlung von der Blendenöffnung aus, wenn kein Glasfaserkabel angeschlossen wird. Wenn Sie Kabel löschen, starren Sie nicht in die geöffneten Blendenöffnungen an. Zusätzlich installieren Sie schützende Blendenöffnung Abdeckungen zu den Faserkanälen ohne das angeschlossene Kabel.

Español: **ADVERTIENDO:** RADIACIÓN DE LASER INVISIBLE. Los lasers emiten la radiación invisible de la abertura cuando no se conecta ningún cable fiber-optic. Al quitar los cables no mire fijamente en las aberturas abiertas. Además, instale las cubiertas protectoras de la abertura a los accesos de la fibra sin el cable conectado.

**WARNING:** TO REDUCE RISK OF ELECTRIC SHOCK, DO NOT REMOVE COVER. NO USER SERVICEABLE PARTS INSIDE. REFER SERVICING TO QUALIFIED SERVICE PERSONNEL.

**WARNING:** UM GEFAHR DES ELEKTRISCHEN SCHLAGES ZU VERRINGERN, LÖSCHEN SIE NICHT ABDECKUNG. KEINE BENUTZER-NÜTZLICHEN TEILE NACH INNEN. VERWEISEN SIE DAS INSTANDHALTEN AUF GEKENNZEICHNETES SERVICE-PERSONAL.

**WARNING:** DO NOT INSTALL THIS PRODUCT IN HAZARDOUS AREAS WHERE HIGHLY COMBUSTIBLE OR EXPLOSIVE PRODUCTS ARE STORED OR USED.



The lightning flash/arrowhead symbol, within an equilateral triangle, alerts the user to the presence of a shock hazard within the product's enclosure.

This product is designed for indoor use only. Do not install this product where excessive moisture or heat are present.

**WARNING:** CHECK THE VOLTAGE available on the mains before connecting mains power. CHECK THE VOLTAGE SELECTOR SWITCH ON THE PRODUCT (if applicable). CHECK THE GROUNDING of the mains power. If rack mounted, CHECK THE GROUNDING of the rack power distribution circuit. Failure to do so could cause injury or death, and could cause damage to this product and equipment connected to it.

**WARNING:** This product has not been evaluated by the U.S. FDA. The manufacturer does not recommend the use of this product in life-support applications where failure or malfunction of this product can be reasonably expected to cause failure of the life-support device or to significantly affect its safety or effectiveness. This product is not recommended for direct use of patient care unless the manufacturer and/or its representative have received written assurances that (a) the risks of injury or damage have been minimized, (b) that customer assumes all risk, and (c) the liability of the manufacturer is limited to only the product value.



**RACK MOUNTING:** Make sure that units are installed to get enough air flow for safe operation.

The maximum temperature for rack-mounted units is 40°C (104°F).

Avoid uneven loading or mechanical instability when rack-mounting units.

Check product label for power supply requirements to assure that no overloading of supply circuits or overcurrent protection occurs.

Mains grounding must be reliable and uncompromised by any connections.

**CAUTION:** When replacing the internal fuse, ensure that only the same type is used.

**CAUTION:** This equipment has been tested and found to comply with the limits for a Class "A" digital device, pursuant to part 15 of the FCC Rules. These limits are designed to provide reasonable protection against harmful interference when the equipment is operated in a commercial environment. This equipment generates, uses and can radiate radio frequency energy and, if not installed and used in accordance with the instruction manual, may cause interference to radio communications. Operation of this equipment in a residential area is likely to cause harmful interference in which case the user will be required to correct the interference at their own expense.

Changes or modifications not expressly approved by the party responsible for compliance could void the user's authority to operate the equipment.

**NOTE:** This product was FCC verified under test conditions that included the use of shielded I/O cables and connectors between system components. To be in compliance with FCC regulations, the user must use shielded cables and connectors for all except power and alarm cables.

This digital apparatus does not exceed the Class A limits for radio noise emissions as set out in the Radio Interference Regulations (ICES-003) of the Canadian Department of Communications.

Le présent appareil numérique n'émet pas de bruits radioélectriques dépassant les limites applicables de la Classe A prescrites dans le Règlement (ICES-003) sur le brouillage radioélectrique édicté par le Ministère des Communications du Canada.

---

## About this Guide

This installation guide gives detailed procedures for installing, troubleshooting, and servicing the OMNInet system components. Other related OMNInet Fiber-Optic Network documents are:

- *PathMaster System Control Guide*, 8000-2849-02
- *PathMaster System Design Guide*, 8000-2849-03
- *PathMaster Software Installation Instructions*, 8000-2849-04

### If you need assistance...

Contact your Sales Representative.

---

## About the Product

The OMNInet system is a multimedia fiber optic routing network. It consists of hardware chassis, or nodes, that are interconnected with fiber optic cabling. A node consists of a 3RU 48.3cm (19") chassis with a 14-slot backplane, power supply, and a fiber optic interface card. Each chassis must contain at least one fiber optic interface card and any combination of Data, Video, and Audio I/O (input/output) modules. The customer's video and audio systems connect to the I/O modules in the OMNInet chassis.

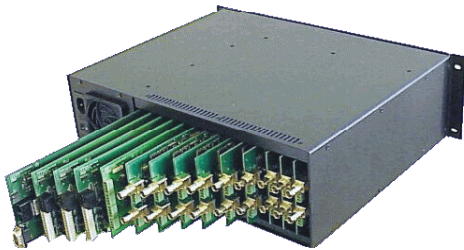

All OMNInet chassis are shipped to the customer's site with the applicable I/O cards pre-installed and tested. The chassis are installed into standard 19-inch equipment racks and are connected together with fiber-optic cables. The customer's cameras, domes, monitors, video switches, and audio system are then connected to the node's I/O cards, as applicable.

Once connected, the OMNInet system is designed, configured, and tested using the PathMaster™ software from a PC at any node location.

For an overview of the OMNInet system, see the *PathMaster System Control Guide*.

**Note:** If any I/O modules are installed or changed at the customer site, the PathMaster Design file must be updated (see instructions in the *PathMaster System Design Guide*).

---

## Installation

All OMNInet equipment is shipped to the installation site in boxes that identify the equipment and its network installation location. Because each installation is customized to the customer's specifications, a System Configuration Drawing accompanies the equipment. This drawing identifies the system components, their installation location, and all input and output connections.

The OMNInet chassis are identified as *nodes*, beginning with a Source Node. Installation locations can consist of one or more nodes that are equipped with the appropriate input/output modules (cards) for that location.

**Important!** Any time cards are added to or changed in an OMNInet chassis, you must update the PathMaster Design File. For instructions, see the *PathMaster System Design Guide*.

## Parts Required

- Hardware to mount the OMNInet chassis in the equipment rack
- Fiber cable terminations: Type SC

Recommended cable types:

- Fiber optic:
  - Multimode: 50/125 or 62.5/125 Micron graded index
  - Single Mode: 8/125 Micron graded index
- Audio: Shielded, twisted pair
- Video: RG-59/U Coaxial
  - Standard: RPVxxxNx
  - Plenum: RPVxxxPx
- Data: As specified by the customer's equipment manufacturer.

## Tools Required

- Small flat-tip and Phillips screwdrivers

## Installing the OMNInet Chassis

For each node:

1. Unpack the equipment for the node at its installation location. Inspect it for damage.

**IMPORTANT!** Do not remove the rubber feet from the OMNInet chassis.

**Note:** A filler plate is shipped with each chassis. The plate provides space for air circulation.

2. Mount the OMNInet chassis into the equipment rack. Install the filler plate onto the equipment rack, immediately below the chassis.

**CAUTION:** For a dual-voltage chassis, ensure the voltage selector is correctly set.

**Note:** A dual-voltage chassis does not have a power switch.

3. Connect the chassis power cable to the rack's power supply. Turn the power switch to ON (single-voltage chassis only). The green **Power** (top) LED on the FC101 Network Interface module illuminates to indicate DC power is available.

**Note:** If the green **Power** LED does not illuminate, see the **Troubleshooting** section on page 8.

## Connecting Fiber Cables

Refer to the System Configuration Drawing supplied with the equipment. This drawing details the fiber cable connections and the order in which they are to be connected.

### Ring Network

In a Ring network, fiber cables are connected to the nodes in sequence, beginning with the output at the Source Node going to the input at Node 1, and continuing until the output from the last node is connected to the input at the Source Node.

1. Starting at the Source Node, connect the fiber cable going to Node 1 to the **Output** (top) connector on the FC101 module (see **FC101 Network Interface Module** on page 6).
2. At Node 1, connect the fiber cable coming from the Source Node to the **Input** (bottom) connector on the FC101 module. The **Status** (bottom) LED on the FC101 module changes from red to green to indicate a good connection.

If the **Status** LED does not change to green, see the **Troubleshooting** section on page 8.

3. Connect the fiber cable going to the next node to the **Output** (top) connector on the FC101 module.
4. Repeat steps 2 and 3 for each node until you connect the fiber cable from the last node to the **Input** (bottom) connector on the FC101 module at the Source Node.

### Redundant Network

Redundant networks—also called self-healing or contra-rotating networks—are a variation of Ring networks. Two fiber-optic cables run through the network with communication in opposite directions to provide improved system reliability. Refer to the System Configuration Diagram for the fiber cable connection details.

### Star Network

In a Star network, fiber cables are connected from the Source (hub) Node to each of the “Point” or remote nodes. Refer to the System Configuration Diagram for the fiber cable connection details.

### Combination Network

This network consists of a combination of Ring and Star networks. Refer to the System Configuration Diagram for the fiber cable connection details.

## Connecting Signal Cables

Referring to the System Configuration Drawing, connect all video, audio, and data input and output cables to their respective modules in each node. For connection details, see **OMNInet System Components** on page 5.

## Connecting the Host PC

1. Using a cable having USB connectors on both ends, connect the host PC to the FC101 module at any node.
2. Install the PathMaster software onto the PC (see the *PathMaster Software Installation Instructions*).
3. Configure the OMNInet system (see the *PathMaster System Control Guide*).

**Note:** If the Design File (.vu2) was not included with the software, you must create it before the system can be used (see the *PathMaster System Design Guide*).

## OMNinet System Components

For an overview of the OMNinet system, see the *PathMaster System Control Guide*.

### OCHSYS02 System Rack Chassis

This chassis is the basic element in the OMNinet system and operates as a “T-tap” on the fiber optic backbone. All network (fiber optic) I/O modules and multimedia I/O modules plug directly into this backplane. All modules plug in from the rear of the rack.

### PSA02 Universal AC Input Power Supply Module

The PSA02 is a 200-Watt (continuous) - 220-Watt (peak) power supply mounted on a slide-in tray for

easy mounting in the OCHSYS02 chassis. It provides four separate DC outputs to a floating connector that mates with a complementary connector on the chassis backplane.

Figure 1. OMNinet chassis (front cover removed)

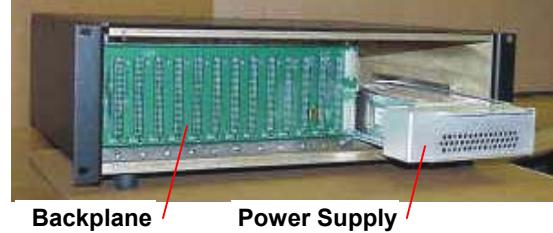

The PSA02 is hot swappable and can be used in a redundant configuration. The input side of the supply is universal and operates correctly with input voltages of 85-264Vac. The unit is fused at the IEC power entry module and can be accessed externally.

Figure 2. The OMNinet chassis (rear view)

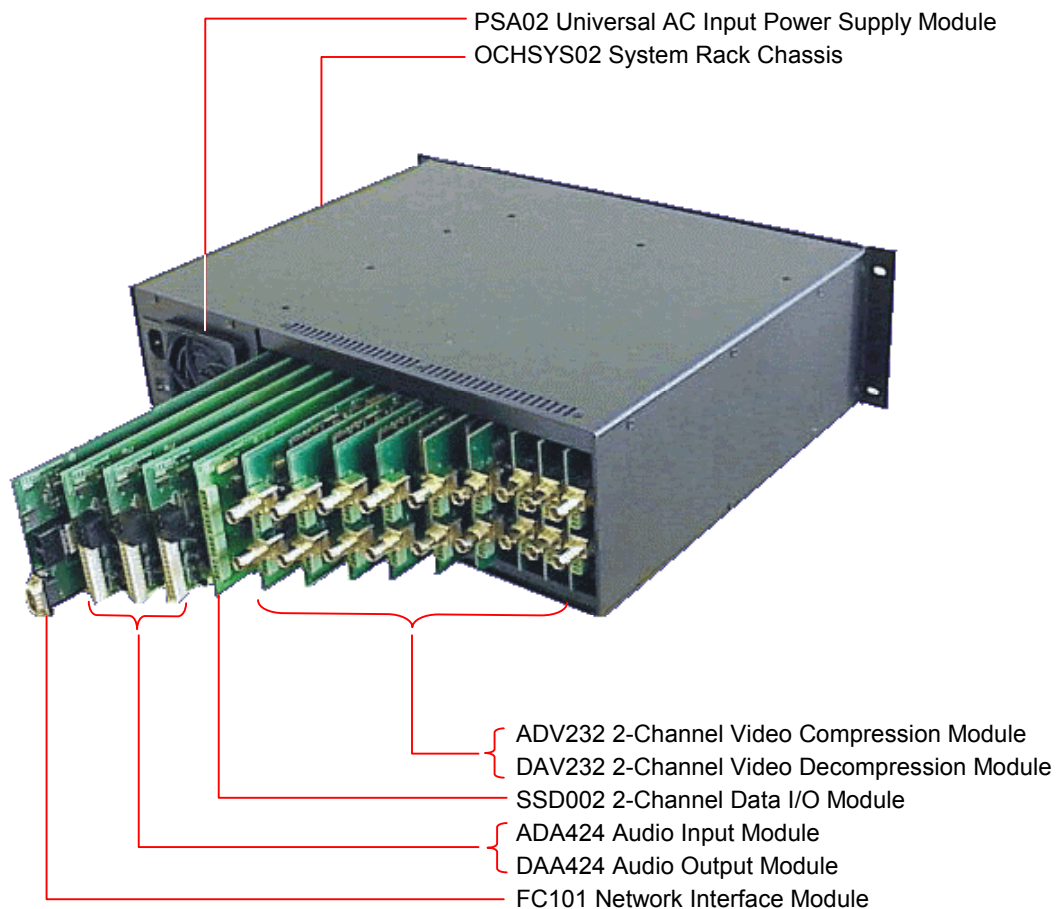

## FC101 Network Interface Module

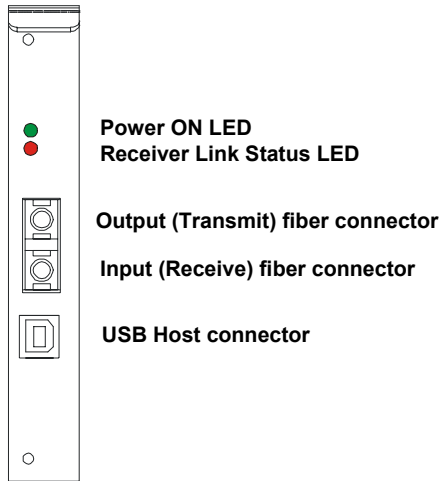

The FC101 is the primary Network Interface Module performing the “T-tap” function on the Fiber Optic Network. It is also responsible for all back-plane management and timing functions. Each FC101 Module represents 1/8 of the total available network bandwidth.

System configuration and control/monitoring information is communicated using the USB port between a host computer and the FC101 Module.

## ADV232 2-Channel Video Compression Module

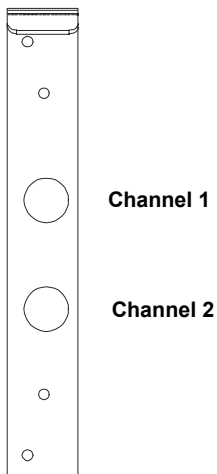

The ADV232 handles luminance and chrominance processing for composite video inputs in various formats including NTSC M, NTSC N, NTSC 4.43, NTSC Japan, PAL M, PAL N, PAL BGHI, and SECAM. The ADV232 performs individually selectable real time compression on both channels at 35:1, 70:1, and 140:1 ratios (set at the design

stage) while maintaining excellent video color and detail.

Because OMNI $net$  is able to switch at both source and destination, literally thousands of video sources (CCTV cameras, etc) can be handled on each network without the need for additional routing/switching equipment. Multiple networks can be linked together to form even larger arrays. At CCTV resolution, bandwidth for up to 512 monitors is available, each of which can select from any active source.

The connection between the output (viewing) location and the video input is automatically made through the network switch fabric.

## DAV232 2-Channel Video Decompression Module

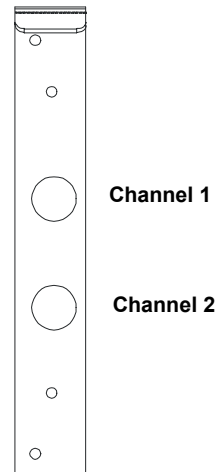

Each output channel on this module is able to select any of the compressed video sources on the OMNI $net$  system regardless of physical location. These digital signals are decompressed and processed to deliver a high quality video output. Output formats include NTSC M, NTSC N, NTSC 4.43, NTSC Japan, PAL M, PAL N, PAL BGHI, and SECAM.

The connection between the output (viewing) location and the video input is automatically made through the network switch fabric.

## ADA424 Audio Input Module

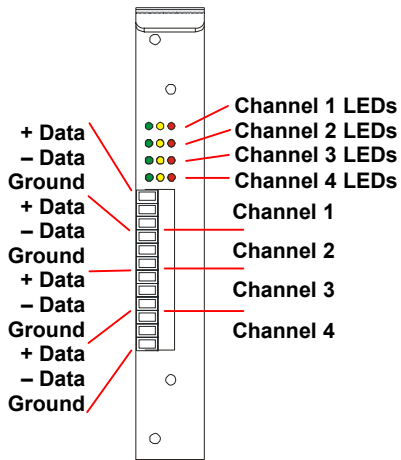

The ADA424 is a 24-bit, 4-channel audio input module. It is designed to accept microphone or line level signals. Each input is individually assignable to any of the 640 available slots on a fully loaded network using the PathMaster configuration software package. For an explanation of the Channel LEDs, see Table 1 on page 8.

## DAA424 Audio Output Module

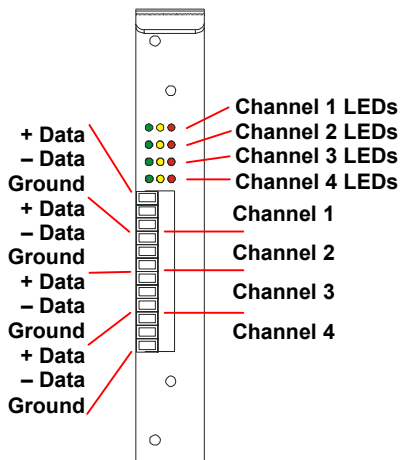

The DAA424 is a 24-bit, 4-channel audio output module. It is designed to select four channels from the chassis backplane and route them through the proper D/A converters for output on the line level drivers. Each output is individually selectable to any of the 640 available slots on a fully loaded network using the PathMaster control software package. For an explanation of the Channel LEDs, see Table 1 on page 8.

## SSD002 2-Channel Data I/O Module

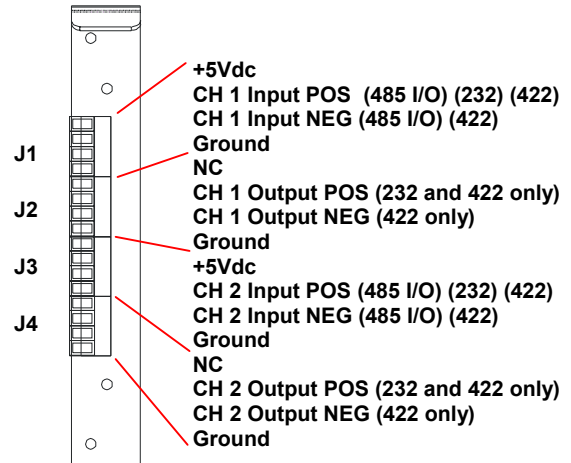

This module is designed to handle slow scan data sources such as those from computer COM ports and other control type data communications. There are two input/output channels on each card, each of which can be assigned to different SubNets within the OMNInet system.

The I/O format is software selectable to RS-232, RS-422, RS-485 (both with and without standard terminations), and SensorNet. When bus communication protocols, such as RS-485 and SensorNet, are used, the input connectors of Channel 1 or 2 are configured as I/O ports. There are also two transfer modes—Normal Transfer Mode (NTM) for data rates up to 300Kb/s, and Fast Transfer Mode (FTM) for data rates up to 24.576Mb/s.

The OMNInet system is capable of handling many different SubNets, each of which can be a different format, even on the same I/O module. See the *PathMaster System Design Guide* for information about SubNets.

Table 1. Audio Channel LEDs

	LED State	Audio Input Card	Audio Output Card
Red LED	Off, Yellow & Green Off	No signal, channel on	Selected on matrix, no signal
	On, Yellow & Green Off	Channel off (software selected) Also used during send current settings	Channel off (not selected on matrix) Also used during send current settings
	On, Yellow & Green On	Clipping signal (distortion)	Clipping signal (distortion)
Yellow LED	On	-24dB reference to signal	-24dB reference to signal
Green LED	Off, Red & Yellow off	No signal	No signal
	On or blinking Yellow	Signal present, normal operation	Signal present, normal operation
	On, Yellow On & blinking Red	Signal present, not best operation	Signal present, not best operation
	On, Red & Yellow On	Clipping signal (distortion)	Clipping signal (distortion)

## Troubleshooting

Problem...	What to check...
Green Power (top) LED on FC101 does not illuminate when power cable is plugged into rack's power supply.	<ul style="list-style-type: none"> <li>■ Verify Power Supply module PSA02 is correctly installed.</li> <li>■ Verify power is supplied to the equipment rack.</li> <li>■ Check chassis fuse (located by the fan). If necessary, replace with same type fuse only.</li> </ul>
Status (bottom) LED on FC101 does not change from red to green when fiber cable from preceding node is connected to Input (bottom) connector.	<ul style="list-style-type: none"> <li>■ Verify fiber cable is connected to Output (top) connector on preceding node and Input (bottom) connector on subject node.</li> <li>■ Verify Input and Output fiber types (single mode or multimode) are the same (do not mix fiber types on the same card).</li> </ul>
Unable to control any module in system.	<ul style="list-style-type: none"> <li>■ Perform computer control verification (see <i>PathMaster Software Installation Instructions</i>).</li> </ul>
Audio not playing through system, no LED activity on Audio Input and Audio Output cards.	<ul style="list-style-type: none"> <li>■ Verify the external audio equipment is playing.</li> <li>■ Verify that proper Audio Input card (gray input connector) is installed.</li> <li>■ *Ensure Audio Input card is installed in proper location.</li> <li>■ Verify cable is properly connected to Audio Input Card.</li> <li>■ If card is loose or has been installed by other than a factory technician, remove card and verify no connector pins are bent.</li> <li>■ Verify chassis address is correct (see <b>Service</b> on page 10).</li> <li>■ Verify that proper system configuration was uploaded from controlling computer.</li> </ul>

Problem...	What to check...
Audio not playing through system, LED activity on Audio Input card but not on Audio Output card.	<ul style="list-style-type: none"> <li>■ Verify that proper Audio Output card (green output connector) is installed.</li> <li>■ *Ensure Audio Output card is installed in proper location.</li> <li>■ If card is loose or has been installed by other than a factory technician, remove card and verify no connector pins are bent.</li> <li>■ Verify chassis address is correct (see <b>Service</b> on page 10).</li> <li>■ Verify that proper system configuration was uploaded from controlling computer.</li> </ul>
Audio not playing through system, LED activity on Audio Input and Audio Output cards.	<ul style="list-style-type: none"> <li>■ *Verify Audio Input and Output cards are installed in proper location.</li> <li>■ Verify cable is properly connected to the Audio Output card.</li> <li>■ Verify external speakers are connected and have power.</li> </ul>
No video output, color bars, or splash screen.	<ul style="list-style-type: none"> <li>■ *Verify Video Output card DAV232 is installed in proper location.</li> <li>■ If card is loose or has been installed by other than a factory technician, remove card and verify no connector pins are bent.</li> <li>■ Verify chassis address is correct (see <b>Service</b> on page 10).</li> <li>■ Verify system file is uploaded to system.</li> <li>■ Reset video output (see System Control Guide).</li> <li>■ Verify external equipment is turned on.</li> </ul>
No video output, but have color bars and splash screen.	<ul style="list-style-type: none"> <li>■ *Verify Video Input card ADV232 is installed in proper location.</li> <li>■ If card is loose or has been installed by other than a factory technician, remove card and verify no connector pins are bent.</li> <li>■ Verify chassis address is correct (see <b>Service</b> on page 10).</li> <li>■ Verify system file is uploaded to system.</li> <li>■ Reset video input card (see System Control Guide).</li> <li>■ Verify external equipment is turned on.</li> </ul>
Data not passed through system.	<ul style="list-style-type: none"> <li>■ Disconnect all external equipment from OMNInet and verify external equipment functions properly.</li> <li>■ Verify the correct data SubNets and data rates within PathMaster are selected for external equipment (see SubNets in System Design Guide).</li> <li>■ *Verify data cards are installed in proper locations and correct data type is selected.</li> <li>■ If any card is loose or has been installed by other than a factory technician, remove card and verify no connector pins are bent.</li> <li>■ Verify chassis address is correct (see <b>Service</b> on page 10).</li> <li>■ Verify connection from external equipment to data card pin-out (see pin-out sheet).</li> <li>■ Verify transmit and receive signals are present on both ends of fiber system.</li> </ul>

\* Use the Design File to verify the proper location for module cards (see the *PathMaster System Design Guide*).

## Service

### Removing the Power Supply Module

**CAUTION:** If chassis has only one power supply, ensure power to the chassis is turned off. If chassis has a redundant power supply, either power supply can be removed or replaced without turning off the power.

1. Loosen three captive screws on the front cover.
2. Lift cover upward and set it aside.
3. Slide the power supply module out of the chassis.

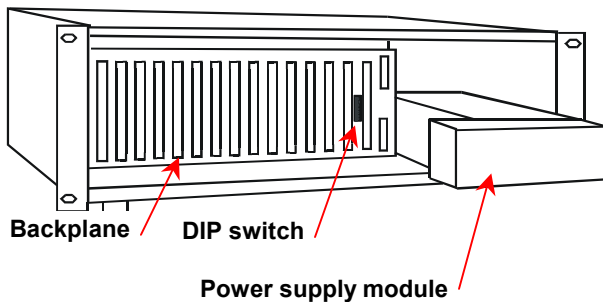

### Installing the Power Supply Module

1. Slide the power supply module into the bottom bay.  
If a second (redundant) power supply module is required, install it into the top bay.
2. Place the front cover on the chassis and tighten the three captive screws.

### Setting or Verifying the Chassis Address

Each OMNInet chassis address is preset at the factory. Use the following procedures to set or verify a chassis address when adding a node to an existing system or to verify the address when troubleshooting.

**CAUTION:** Ensure power is turned off.

1. Loosen three captive screws on the front cover.
2. Lift cover upward and set it aside.

**Note:** The DIP switch is located on the right side of the backplane, near the power supply connector.

DIP Switch		Switch No.	Binary Value
1		1	1
2		2	2
3		3	4
4		4	8
5		5	16
6		6	32
7		7	64
8		8	128

OFF ON

3. If necessary, set the DIP switch to the settings specified in the Design File. Many installations will include a Design File (\*.VU2) as part of the software installation.
4. Place the front cover on the chassis and tighten the three captive screws.
5. Turn on the system power.
6. Using the PathMaster software, upload the new system file to the OMNInet system (see the instructions in the *PathMaster System Control Guide*).

Table 2. Chassis DIP switch settings

Switch #	1	2	3	4	5	6	7	8
Binary value	1	2	4	8	16	32	64	128
SOURCE NODE	0	0	0	0	0	0	0	0
Chassis #1	1	0	0	0	0	0	0	0
2	0	1	0	0	0	0	0	0
3	1	1	0	0	0	0	0	0
4	0	0	1	0	0	0	0	0
5	1	0	1	0	0	0	0	0
6	0	1	1	0	0	0	0	0
7	1	1	1	0	0	0	0	0
8	0	0	0	1	0	0	0	0
9	1	0	0	1	0	0	0	0
10	0	1	0	1	0	0	0	0
11	1	1	0	1	0	0	0	0
12	0	0	1	1	0	0	0	0
13	1	0	1	1	0	0	0	0
14	0	1	1	1	0	0	0	0
15	1	1	1	1	0	0	0	0
16	0	0	0	0	1	0	0	0
17	1	0	0	0	1	0	0	0
18	0	1	0	0	1	0	0	0
19	1	1	0	0	1	0	0	0
20	0	0	1	0	1	0	0	0
21	1	0	1	0	1	0	0	0
22	0	1	1	0	1	0	0	0
23	1	1	1	0	1	0	0	0
24	0	0	0	1	1	0	0	0
25	1	0	0	1	1	0	0	0

**Note:** 1 = ON, 0 = OFF

## Installing a Module Card

**Important!** Any time you add or change cards in an OMNInet chassis, you must update the PathMaster Design File. For instructions, see the *PathMaster System Design Guide*.

**Note:** Either a single-slot blank plate or a breakaway multiple-slot blank plate covers vacant slots in a chassis. Breakaway only the number of sections from a multiple-slot blank plate that is needed for the cards to be installed. Do not break the multiple-slot plate into individual slot plates.

**Note:** You can install a module card into the chassis without turning off the power.

1. If necessary, remove the blank plate covering a vacant slot.
2. Verify that none of the 96 pins of the card's connector are bent.
3. Carefully slide the card into the vacant slot.
4. Apply pressure equally to the top and bottom of the rear edge of the card to seat it into the chassis.
5. Install the holding screws into the top and bottom holes in the card (see below illustration).
6. Update the PathMaster Design File (for instructions, see the *PathMaster System Design Guide*).

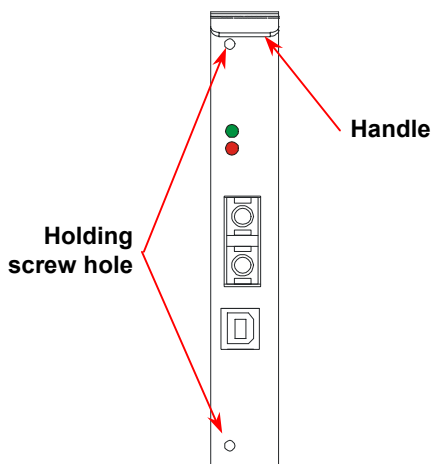

## Removing a Module Card

**Important!** Any time you remove cards from an OMNInet chassis, you must update the PathMaster Design File. For instructions, see the *PathMaster System Design Guide*.

**Note:** You can remove a module card from the chassis without turning off the power.

1. Remove the two holding screws from the card.
2. Use the handle on the module card to pull it out of the chassis.
3. If a module card is not to be placed into the vacated slot, cover the slot with a blank plate (install two screws to secure the plate), and update the PathMaster Design File (for instructions, see the *PathMaster System Design Guide*).

To install a card into the vacated slot, perform the procedures in **Installing a Module Card** above.

## Specifications

### Electrical

Input.....	110/240Vac, 50/60Hz, 1.5A/.75A 110Vac, 60Hz, 1.5A 240Vac, 50Hz, .75A
Inrush Current.....	20A @ 110Vac
Optional redundant online backup 5Vdc power supply	

### Environmental

Operating Temperature .....	0-70°C (32-158°F) at full power
Relative Humidity.....	5 to 85% non- condensing
AC Fan .....	30cfm

### Mechanical

Dimensions (H x W x D).....	13.4 x 48.2 x 35.6cm (5.25 x 19 x 14in.)
Unit Weight* .....	9.06kg (20 lbs)
Shipping Weight* .....	11.09kg (24.5 lbs)
*Fully Loaded	

### Connectors

Data .....	Mini-Phoenix
Audio .....	Mini-Phoenix
Video .....	BNC
Card Slots.....	14 total

### Operational

Segment Bandwidth .....	147.456Mb/s
Total Segments .....	8
Total Network Bandwidth.....	1,179.648Mb/s
Optical	
Standard Wavelength .....	1310nm
Standard Optical	
Power Budget .....	10dB (MM)
Optional Wavelength .....	1550nm
Optional Optical	
Power Budget .....	25dB (SM)
Bit Error Rate .....	$2.5 \times 10^{-10}$

### Data

Data Formats* .....	RS-232, -422, -485, SensorNet
Communication Mode .....	Bus/Point to Point
Data Rates* .....	0-300kb/s
Sampling Method .....	10x oversampling
Protocol Limitations.....	None
Network Data Delay .....	40µs + fiber path delay

\*Software Selectable

### Audio

Maximum Input Level.....	+24dBu
Frequency Response .....	10Hz to 22kHz
Resolution .....	16, 20, and 24 bits
Dynamic Range.....	94, 104, and 108 db
THD + N (20 bits) .....	0.004% typical
Sample Rate .....	48kHz

### Video

Input Level.....	1.0Vp-p
Input Impedance .....	75Ω, 3.3kΩ
Line/Field Tilt Distortion.....	0.8°
Horizontal Resolution .....	720
Number of Lines/Field	
NTSC/CCIR.....	243
PAL/EIA.....	288
Luma Non-linearity .....	0.8°
Chroma-Luma Delay	
Inequality .....	1.0ns
Differential Gain .....	0.8%
Differential Phase.....	0.8°
NTSC Frequency Response	
Luma .....	7.5MHz
Chroma .....	3.6MHz
PAL Frequency Response	
Luma .....	8.0MHz
Chroma .....	4.0MHz
Wavelet Resolution .....	8.0bits
Wavelet SNR .....	48dB

---

## Part Numbers

### System Level Devices

OCHSYS02 .....Network chassis with power supply

### Fiber Transceiver/Network Interface Cards

FC101MM .....Multi-mode, single data segment, up to 3 km (1.86 miles)  
FC101SM .....Single-mode, single data segment, up to 15 km (9.32 miles)  
FC104SM .....Single-mode, four data segment, up to 15 km (9.32 miles)  
PSA02 .....Optional secondary power supply  
PATH .....PathMaster System Configuration and Control Software

### Logic and Control Modules

SSD002 .....Slow scan data module, bi-directional, up to 256K baud mini-phenix connectors (2 in/2 out)  
SCS801 .....8-channel switch closure sense module  
SCD801 .....8-channel switch closure drive module

### Audio Signal Modules

ADA424 .....4-input mic/line analog audio module, 24-bit, 48kHz sample rate  
DAA424 .....4-output analog audio module, 24-bit, 48kHz sample rate

### Video Signal Modules

ADV232 .....2-input video module (digitizes two composite analog signals)  
DAV232 .....2-output video module (decodes two composite signals)

---

## Declarations

### Regulatory Compliance

#### Satisfying CE Mark:

Alarm Systems.....EN50130-4

#### Emissions:

Class A Radiated Emissions .....EN55022 (CISPR22)  
Class A Conducted Emissions .....EN55022  
Harmonics .....EN61000-3-2  
Flicker .....EN61000-3-3

#### Immunity:

Over and under voltage tolerance ....EN50130-4 Sect 7  
Voltage Dips and Interruptions .....EN50130-4 Sect 8  
ESD .....EN50130-4 Sect 9  
Radiated Susceptibility.....EN50130-4 Sect 10  
Conducted Susceptibility.....EN50130-4 Sect 11  
Electrical Fast Transients.....EN50130-4 Sect 12  
Lightning Surge.....EN50130-4 Sect 13

#### Safety:

UL and cUL Listed UL60950: 3rd Edition  
TUV Licensed EN60950:2000

**EQUIPMENT MODIFICATION CAUTION:** Equipment changes or modifications not expressly approved by Sensormatic Electronics Corporation, the party responsible for FCC compliance, could void the user's authority to operate the equipment and could create a hazardous condition.

See About the Product on page 3.

## Other Declarations

**WARRANTY DISCLAIMER:** Sensormatic Electronics Corporation makes no representation or warranty with respect to the contents hereof and specifically disclaims any implied warranties of merchantability or fitness for any particular purpose. Further, Sensormatic Electronics Corporation reserves the right to revise this publication and make changes from time to time in the content hereof without obligation of Sensormatic Electronics Corporation to notify any person of such revision or changes.

**LIMITED RIGHTS NOTICE:** For units of the Department of Defense, all documentation and manuals were developed at private expense and no part of it was developed using Government Funds. The restrictions governing the use and disclosure of technical data marked with this legend are set forth in the definition of "limited rights" in paragraph (a) (15) of the clause of DFARS 252.227.7013. Unpublished - rights reserved under the Copyright Laws of the United States.

**TRADEMARK NOTICE:** OMNI*net*, Path*Master*, Sensormatic, and the Sensormatic logo are trademarks or registered trademarks of Sensormatic Electronics Corporation. Other product names mentioned herein may be trademarks or registered trademarks of Sensormatic or other companies.

No part of this guide may be reproduced in any form without written permission from Sensormatic Electronics Corporation.

CSD: 06/2002